

KTM FIRE DAMPER



SMAN

Intended use:

The KTM type fire dampers are intended to installation in general ventilation systems as cut-off baffles, separating the fire zone from the remaining part of the building (normally open).

Intended use

The KTM type fire dampers are intended to installation in general ventilation systems as cut-off baffles, separating the fire zone from the remaining part of the building (normally open). The basic function of the KTM type fire dampers is to restrain the spreading of fire, temperature and smoke.

The fire dampers, independently to the axis of rotation of the flap (with the axis angle $0 \div 360^\circ$) are intended for horizontal (in walls) and vertical installation (in ceilings).

These fire dampers can be mounted in rigid and light weight partition building barriers. The KTM has fire resistance class **EI120 (ve ho i↔o) S** and **EI90/60/30 (ve i↔o) S**, which means that the damper has integrity, insulation and smoke leakage not less than 120/90/60/30 minutes, depending on fire barrier type and thickness. For more details check Declaration of Conformity KTM.

The fire dampers can be also installed in building barriers with lower fire resistance class than EI120. In such use the fire damper has the fire resistance equal to the fire resistance class of the building barrier with smoke leakage criteria maintained.

Fire damper is constructed, manufactured and tested in accordance with the standards: **PN-EN 15650** "Ventilation for buildings – Fire dampers" and **PN-EN 13501-3** "Fire classification of construction products and building elements- Part 3: Classification using data from fire resistance tests on products and elements used in building service installations: fire resisting ducts and fire dampers".

Sensitivity of the fire dampers is confirmed by tests in accordance with the standard **EN 1366-2**. "Fire resistance tests for service installations- Part 2: Fire dampers".

Dampers KTM type fire resistance classification

EI 120 (ve ho i↔o) S

- Ceilings having a density ($2200 \pm 200 \text{ kg/m}^3$) or more, having a thickness of 150 mm or more and having fire resistance class EI 120 or higher
- Rigid walls having low density ($650 \pm 200 \text{ kg/m}^3$) or more, having a thickness of 115 mm or more and having fire resistance class EI 120 or higher (for example: concrete, masonry of solid brick, cellular concrete blocks or airbricks and panels).
- Standard walls having a thickness of 125 mm or more and having fire resistance class EI 120 or higher (thicker, denser, more layers of boards)

EI 90 (ve i↔o) S

- Standard walls having a thickness of 100 mm or more and having fire resistance class EI 90 or higher (thicker, denser, more layers of board),
- Rigid walls having a thickness of 100 mm or more and having fire resistance class EI 90 or higher (for example: concrete, masonry of solid brick, cellular concrete blocks or airbricks and panels),
- Away from rigid walls having low density of ($650 \pm 200 \text{ kg/m}^3$) or more, having a thickness of 120 mm or more and having fire resistance class EI 90 or higher (for example: concrete, masonry of solid brick, cellular concrete blocks or airbricks and panels),

EI 60 (ve i↔o) S

- Rigid walls having a thickness of 100 mm or more, having density 520 kg/m^3 or more and having fire resistance class EI 60 or higher.

EI 30 (ve i↔o) S

- Standard walls having a thickness of 75 mm or more and having fire resistance class EI 30 or higher (thicker, denser, more layers of board).

Key:

- E** – Integrity,
- I** – Insulation,
- S** – Smoke leakage,
- ve** – Damper installed in vertical compartment (wall),
- ho** – Damper installed in horizontal compartment (ceiling),
- i↔o** – The fire performance criteria are met on both sides.
- 120/90/60/30** – Classification time in which criteria E and I are met, expressed in minutes

The fire dampers can be also installed in building barriers with lower fire resistance class. In such use damper has the fire resistance equal to the fire resistance class of the barrier with smoke leakage criteria maintained.

Installation in both, vertical and horizontal axis of rotation of the damper's blade is acceptable (with the axis angle $0 \div 360^\circ$).



Technical description

The KTM type fire damper (with return spring) and KTM-E (with electric actuator and return spring) consist of casing with round cross-section, moveable blade and closure mechanism with sensing element.

The casing of the damper is made of galvanized steel. On both casing ends there are couplings (male or female) allowing easy connection of the damper with the ductwork elements.

The intumescent gasket was attached on the internal and external surface of the housing, in place of perforation around the closed blade. The feature of this gasket is that, under the influence of high temperatures, it increases its volume and fills thoroughly all the leaks and between the blade and the body.

The moveable blade is made of silicate calcium board. On the perimeter of the blade there is gasket that ensures air tightness at ambient temperature.

The KTM fire damper has actuating springs, which during the opening of the blade are storing the energy that is used for closing. The opened position of the flap is provided by thermal fuse with 70°C±5°C nominal reaction temperature. The closing of the blade takes place after thermal fuse reaction. After exceeding the nominal temperature thermal fuse breaks, causing transition of the blade to the closed position through the operation of the springs. The movement of the blade is limited by the bumper.

The damper KTM-E is equipped with the BELIMO BFL or BF electric actuator with BAT 72 °C or BAE 72 °C thermoelectric tripping device (optionally 95 °C), which forms the drive mechanism of the damper with power supply of AC 230V or AC/DC 24V. Automatic closing of the blade is realized by thermoelectric device, its reaction causes power loss to the electric actuator. With no power supplied to the actuator, the return spring moves the blade to the fully closed position.

During normal operation, the KTM and KTM-E damper blade is in the open position. In case of fire, the transition of the blade to fully closed position occurs.

Versions of KTM dampers

Dimensional series of the KTM type fire dampers include the diameters from DN100 to DN250. The basic dimensional series of the diameters: **DN100, DN125, DN160, DN200, DN250**.

The KTM are manufactured with **female** or **male** coupling.

Depending on the intended use and used actuating mechanism, the fire dampers are marked with the following symbols:

- **KTM** – fire dampers with return spring,
- **KTM-E** – fire dampers with electric actuator and return spring,
- **KTM-ME** – fire dampers with electric actuator and return spring, intended for frequent opening and closing, with possibility to use for the air flow regulation or pressure regulation during normal operation of the general ventilation system.

The length of the KTM fire damper can be 150÷350 [mm] for the female coupling and 195÷395 [mm] for the male coupling. In case of KTM-E(ME) length is 262÷462 [mm] for the female coupling and 307÷507 [mm] for the male coupling.

The basic series of lengths are the following:

- **150 mm** – KTM with female coupling,
- **195 mm** – KTM with male coupling,
- **262 mm** – KTM-E with female coupling,
- **307 mm** – KTM-E with male coupling.

On request, the dampers can be provided with limit switches that indicate closed position, open position or both switches.

In the special chemical-resistant version, all steel components are made of acid-resistant steel, blade is impregnated with non-solvent substance which is used to impregnate fireproof boards.

Weight of KTM dampers

Table 1. Weight of KTM dampers.

DN	KTM Female	KTM Male	KTM-E Female	KTM-E Male
100	0,8	0,9	3,1	3,2
125	0,9	1,0	3,3	3,4
160	1,1	1,3	3,7	3,9
200	1,4	1,6	4,1	4,3
250	1,7	2,0	4,6	4,9

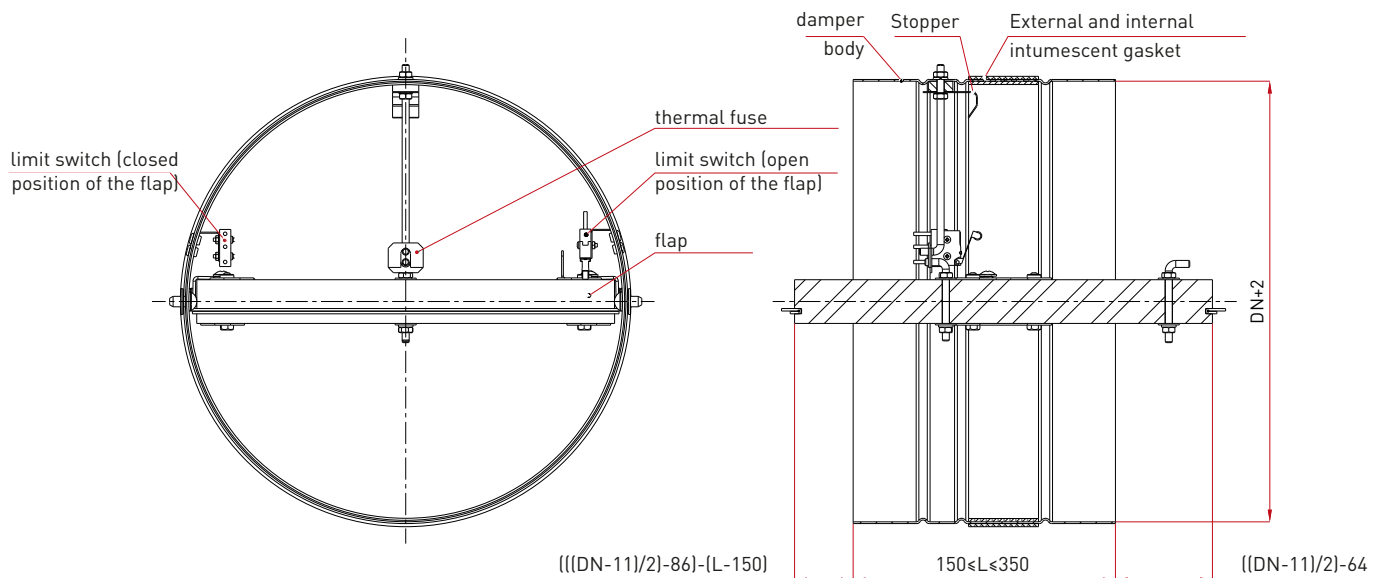

Figure 1. KTM - female coupling.

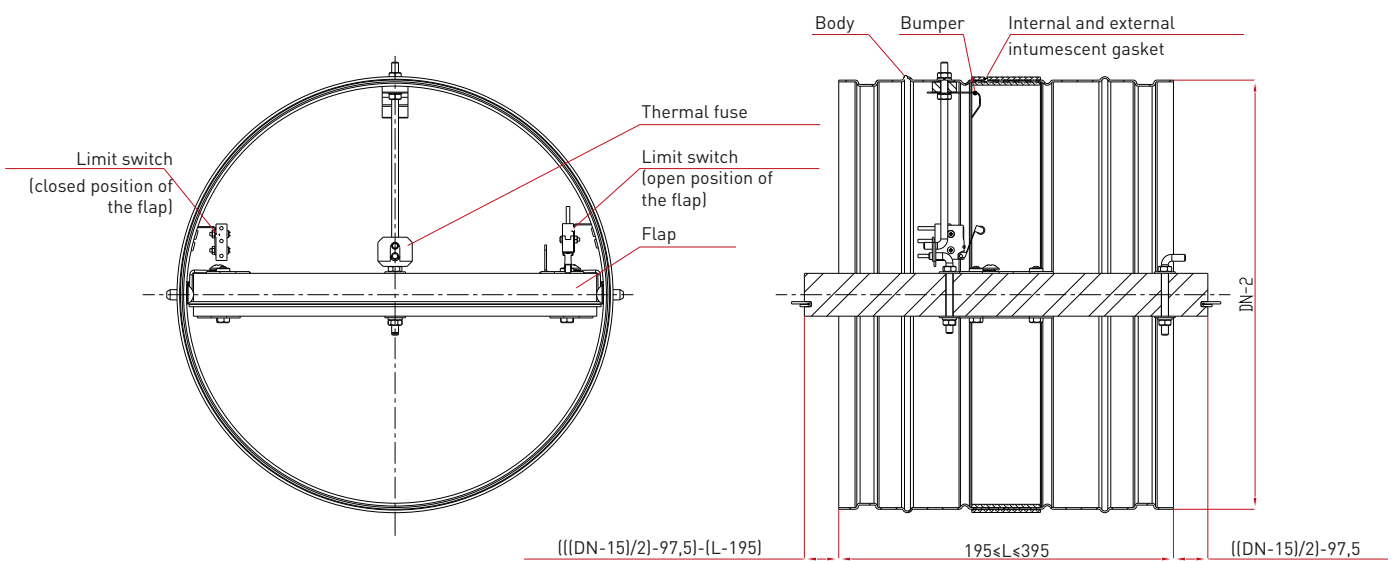

Figure 2. KTM - male coupling.

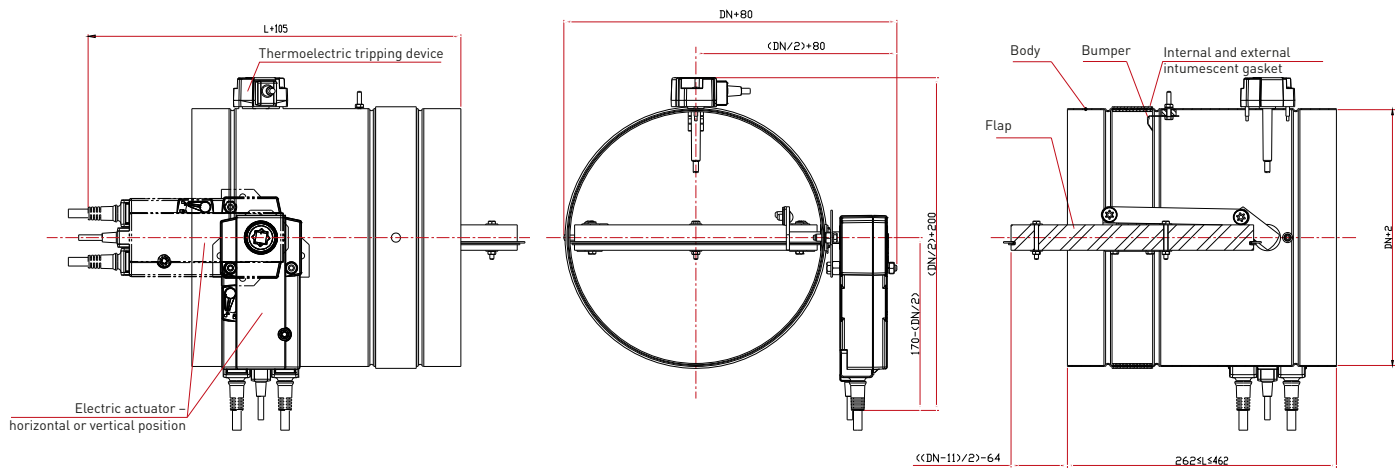

Figure 3. KTM-E - female coupling.

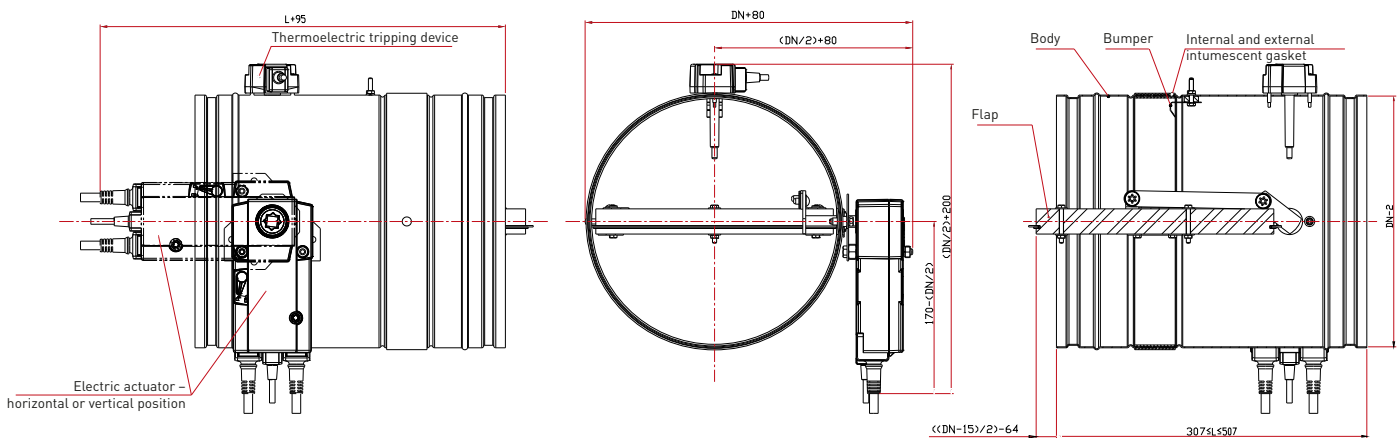

Figure 4. KTM-E - male coupling.

Characteristics of the pressure loss

Table 2. Pressure loss caused by KTM.

V [m/s]	DN [mm]	A _{eff} [m ²]	W _{eff} [m/s]	V [m ³ /h]	ΔP [Pa]
1	100	0,005	1	18	1
2	100	0,005	2	36	3
3	100	0,005	3	54	6
4	100	0,005	4	72	11
5	100	0,005	5	90	17
6	100	0,005	6	108	25
7	100	0,005	7	126	34
8	100	0,005	8	144	45
9	100	0,005	9	162	57
10	100	0,005	10	180	70

V [m/s]	DN [mm]	A _{eff} [m ²]	W _{eff} [m/s]	V [m ³ /h]	ΔP [Pa]
1	125	0,008	1	29	0
2	125	0,008	2	58	2
3	125	0,008	3	86	4
4	125	0,008	4	115	7
5	125	0,008	5	144	10
6	125	0,008	6	173	15
7	125	0,008	7	202	21
8	125	0,008	8	230	27
9	125	0,008	9	259	34
10	125	0,008	10	288	42

V	DN	A _{eff}	W _{eff}	V	ΔP
[m/s]	[mm]	[m ²]	[m/s]	[m ³ /h]	[Pa]
1	160	0,015	1	54	0
2	160	0,015	2	108	1
3	160	0,015	3	162	2
4	160	0,015	4	216	4
5	160	0,015	5	270	7
6	160	0,015	6	324	10
7	160	0,015	7	378	13
8	160	0,015	8	432	17
9	160	0,015	9	486	21
10	160	0,015	10	540	27

V	DN	A _{eff}	W _{eff}	V	ΔP
[m/s]	[mm]	[m ²]	[m/s]	[m ³ /h]	[Pa]
1	200	0,025	1	90	0
2	200	0,025	2	180	0
3	200	0,025	3	270	1
4	200	0,025	4	360	2
5	200	0,025	5	450	3
6	200	0,025	6	540	4
7	200	0,025	7	630	6
8	200	0,025	8	720	7
9	200	0,025	9	810	9
10	200	0,025	10	900	11

V	DN	A _{eff}	W _{eff}	V	ΔP
[m/s]	[mm]	[m ²]	[m/s]	[m ³ /h]	[Pa]
1	250	0,041	1	148	0
2	250	0,041	2	295	0
3	250	0,041	3	443	1
4	250	0,041	4	590	2
5	250	0,041	5	738	2
6	250	0,041	6	886	4
7	250	0,041	7	1033	5
8	250	0,041	8	1181	6
9	250	0,041	9	1328	8
10	250	0,041	10	1476	10

Key:

DN – Nominal diameter of the damper [mm],

A_{eff} – Actual surface [m²],

W_{eff} – Effective velocity measured in actual surface [m/s],

V – Flow volume [m³/h],

Δp – Pressure loss [Pa]

Table 3. Noise level emitted by KTM.

V [m.s]	D [mm]			
	100	125	160	200
L _{WA} [dB _A]				
2	19	18	19	19
4	27	29	22	24
6	39	39	34	36
8	47	45	42	45
10	53	51	49	52

KTM - Shut-off fire damper

While ordering please provide information according to the following method:

KTM - <X> - <DT> - <L> - <W> - <O> - <S> - <UP> - <P> - <RAL> - <Q>

Where:

X	Version	<p>none - with return spring</p> <p>E - with electric actuator and return spring</p> <p>ME - with electric actuator and return spring, intended for frequent opening and closing with possibility to use for the air flow regulation or pressure regulation during normal operation of the general ventilation system</p>
D	Nominal diameter, [mm]: 100, 125, 160, 200, 250	
T	Variant	<p>M - female coupling</p> <p>N - male coupling</p>
L	Length [mm]*	<p>150 - for variant: female coupling with return spring</p> <p>195 - for variant: male coupling with return spring</p> <p>262 - for variant: female coupling with electric actuator</p> <p>307 - for variant: male coupling with electric actuator</p>
W	Limit switch (refers only to KTM)*	<p>none - no limit switches</p> <p>W1 - limit switch indicating closed position</p> <p>W2 - limit switch indicating open position</p> <p>W12 - both limit switches indicating closed and open position</p>
O	Position of the actuator*	<p>V - vertical</p> <p>H - horizontal</p>
S	Actuator type (refers only to KTM-E)	<p>seria BFL - DN ≥ 100 mm</p> <p>seria BF - DN ≥ 100 mm</p>
		<p>Explanation:</p> <p>T - thermoelectrical tripping device</p> <p>ST - connection with plug</p> <p>SR - modulating control type</p> <p>TL - communicative control type</p> <p>24/230 - nominal voltage</p>
UP	Gaskets on connectors*	<p>none - without gaskets</p> <p>UP - gaskets mounting</p>
P	Finish*	<p>none - galvanized steel</p> <p>SN - stainless steel</p> <p>SL - varnished steel</p>
RAL	Painting (for SL)*	
Q	Inspection*	<p>none - no inspection hole</p> <p>R - inspection hole</p>

* optional values - default values will be used if optional values are not specified

Order example:

KTM-100M-W12

KTM-E-250N-H-BF24TL-T-ST-UP-SN



For fire dampers made in special version with increased resistance to corrosion (stainless or painted), the flap will be coated with impregnating substance.